

Anchors for covers

Self-drilling fastener A2 stainless steel

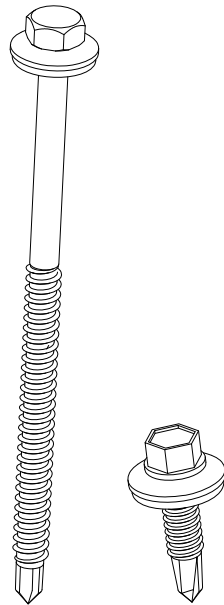

- For fixing steel/aluminium profiles to thin steel/ aluminium substructure. Steel sections from 0.7 to 1.6mm in thickness .
- A2 Austenitic Stainless Steel fastener with Carbon steel drill point.
- It includes sealing washer stainless steel Ø16mm with EPDM pre-assembled.
- Drive: hexagon A/F8
- Approvals:
 - Z-14.4-407
 - Z-14.1-537
 - ETA-10/0200

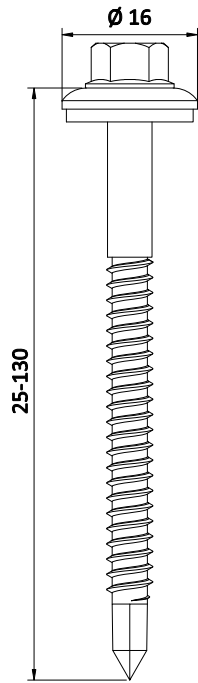

Reference	Name
1.06.0008-2516	A2 Austenitic Stainless Steel fastener with 9mm drill point + EPDM 5,5x25mm
1.06.0008-5016	A2 Austenitic Stainless Steel fastener with 9mm drill point + EPDM 5,5x50mm
1.06.0008-9016	A2 Austenitic Stainless Steel fastener with 9mm drill point + EPDM 5,5x90mm
1.06.0008-13016	A2 Austenitic Stainless Steel fastener with 9mm drill point + EPDM 5,5x130mm
1.06.0009-2516	A2 Austenitic Stainless Steel fastener with 9mm drill point + EPDM 6.0x25mm

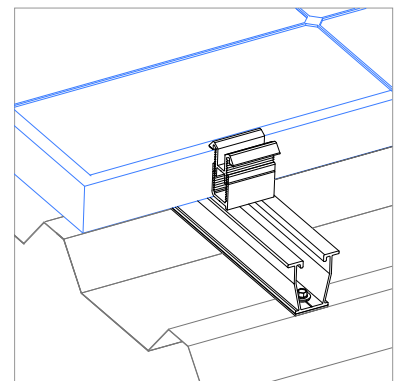
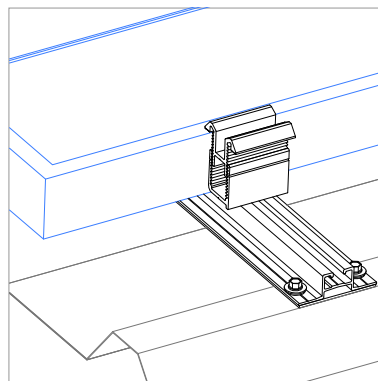
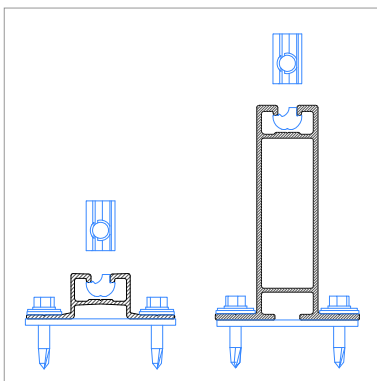

Fijaciones a cubierta

Tornillo auto-taladrante acero inoxidable A2 punta acero

MECHANICAL PROPERTIES	Approval
1.06.0008 fastener	Z-14.1.537 / Z-14.4.407 / ETA-10/2000
1.06.0009 fastener	Z-14.1.537 / Z-14.4.426

DIMENSIONS

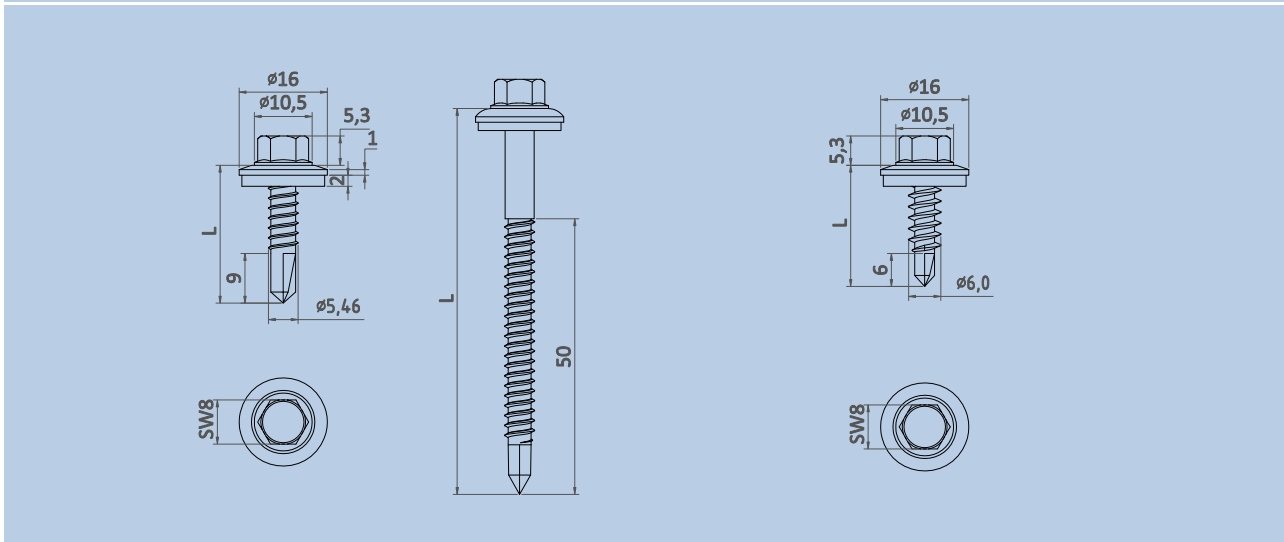

1.06.0008 fastener	1.06.0009 fastener
--------------------	--------------------

INSTALLATION PARMETERS

FASTENER	DRILLING SUITABILITY	Screwing rotation speed rpm
1.06.0008	$t_I + t_{II} = 1,0 + 5,0 \text{ mm}$	1300
1.06.0009	$t_I + t_{II} = 1,0 + 1,0 \text{ mm}$	1800

